

## Intepro 9000 Series

### AC Source ACS 1008

- Precision Measurements for TRMS Voltage, TRMS Current, Peak Current, Crest Factor, Real Power and Power Factor
- Dual output voltage ranges of 0-150V to 0-300V and a frequency range of 16-5000Hz at a power level of 2000VA
- High Peak Current Capability



AC Source Module

This highly efficient AC source enables low cost testing at high speed. Selectable input voltage ranges allow this product to be used anywhere in the world to provide a convenient source of variable utility power for the testing and evaluation of domestic and commercial equipment. All common line voltage and frequency combinations are covered.

The use of high quality components and carefully planned internal layout combine to produce a unit with an exceptionally wide frequency range and precise output voltage regulation.

Comprehensive overcurrent, overvoltage and overtemperature protection also maintain reliability and maximum performance in the harshest and most demanding environments throughout the lifetime of the product.

The ACS1008 comes as standard with IEEE-488 Interface. All functions of the ACS1008 are programmable over the IEEE-488 bus.

Front panel rotary controls can also be used to set voltage and frequency. These controls have an analog feel, with the precision and reliability of digital circuits. Settings and measurements can be read directly on the large, high contrast LCD displays.

Dual output voltage ranges of 150 Vrms L-N and 300 Vrms L-N, provide maximum current at the required voltage.

The output frequency can be varied from 16Hz up to 5000Hz to cover commercial, avionics and defence power applications.

An integrated precision digital sinewave generator facilitates the production of a low distortion output. Dual LCD readouts enhance clarity and visual display of programmed settings for voltage, current limit and frequency.

Precision measurement of voltage, current, peak current and power are performed over the IEEE bus therefore removing the need for external measuring equipment in many cases.

The small form factor and low weight of the ACS1008 make it convenient to use in a variety of locations.

The ACS1008 uses closed case calibration for both output and measurement calibration, lowering cost of ownership.

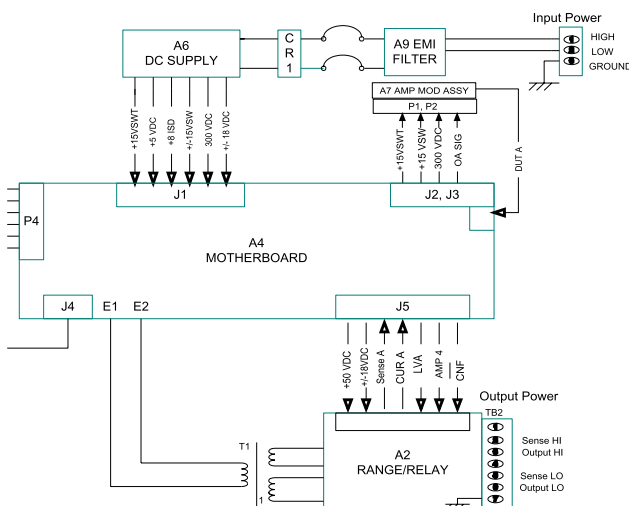

## Technical Specifications

### Input

<b>Line Voltage</b>	103V-127V or 187-253V rms	<b>Line Current</b>	< 30 Arms
<b>Line Frequency</b>	47Hz - 440Hz	<b>Hold up time</b>	10ms

### Output

	Range	Resolution	Accuracy
<b>Voltage</b>	0 - 150V rms or 0 - 300V rms	0.1V	±0.1%FS, 16Hz to 100Hz ±0.2%FS, 100Hz to 5000Hz
<b>RMS Current</b>	6.7Arms / 13.4 Arms	N/A	Programmed value +5% of maximum rms current
<b>Peak Current</b>	22.2A / 44.5A	N/A	
<b>Frequency</b>	16Hz to 5000Hz	0.01Hz (16Hz to 80Hz) 0.1Hz (80.1Hz to 800Hz) 1Hz (800Hz to 5000Hz)	±0.02% of programmed value

**Total Power** 2000VA maximum

Measurement	Range (Low / High)	Resolution	Accuracy
<b>Voltage</b>	0 - 300Vrms	0.1Vrms	0.1%FS + 0.05% reading
<b>Current</b>	4Arms / 15Arms	0.001Arms/ 0.01Arms	0.2%FS + 0.3% reading
<b>Peak Current</b>	12A / 50A	0.01A / 0.1A	0.5%FS + 0.5% reading
<b>Power</b>	800W / 2000W	0.2W	0.5%FS
<b>Power Factor</b>	0.00 - 1.00	0.01	0.05

<b>Operating Temp</b>	0°C to 40°C	<b>Storage Temperature</b>	40°C to 85°C
<b>Dimensions</b>	427mm (w) x 89mm (H) x 560mm (D)	<b>Humidity</b>	90% RH up to 40°C (Operating)
<b>Storage</b>	-40°C to 85°C		
<b>Connections</b>	RS232C Interface - DB9, IEEE-488 Interface - D-Shell 24 pin, AC input - IEC 320, Output - Terminal Strip		

### Family Specifications

<b>Input Isolation Voltage</b>	Input to output=2200VAC, input to chassis=1350VAC
<b>Input Overcurrent</b>	Circuit breaker
<b>Output Overcurrent</b>	Constant current operation (standard)
<b>Output Short Circuit</b>	Peak current limit-shut down
<b>Over Temperature</b>	Automatic shutdown
<b>Input Overvoltage Transients</b>	Surge protection against EN50082-1Regulatory
<b>Electromagnetic</b>	Emissions & Immunity: meets EN50081-1 & EN50082-1 standards
<b>Acoustic Noise:</b>	65 dBA maximum at 0% to 50 % load, 75 dBA maximum greater than 50% load to 100% load
<b>Safety:</b>	Designed to meet UL3111 and EN61010-1 European safety standards as required to the "CE" mark Intake holes on the sides of the power source and the cooling fan at the rear must not be obstructed

### Ordering Information

Part No. 888-2022  
Description ACS1008 AC Source

### Options

Output voltage ranges available for additional voltage and maximum current combinations  
IEEE functions- SH1, AH1, T8, L3, RL2 RS232C Settings - 19200, 8, n, 1



**Intepro Systems**  
1530 S. Lyon Street  
Santa Ana, CA 92705  
+1.714.679.9749  
+1.714.835.3441 (Fax)

**EU/Ireland**  
Intepro Systems  
Lonsdale Road  
National Technology Park  
Limerick / Ireland  
+353.61.33.22.33  
+353.61.33.25.84 (Fax)

**UK**  
Intepro Systems  
Ashville Way  
Molly Millar's Lane  
Wokingham / UK  
+44.118.977.0070  
+44.118.979.2969 (Fax)