

DC/DC Burn-in Test Systems

ATE Systems

- Recycles >80% of loading energy
- Programmable control and measurement
- Flexible load options - recycling/active/passive resistive
- Output voltage solutions down to 0.8V
- Expandable
- Multi-channel electronic load



Typical 45 EUT Burn-in Systems

Intepro's range of new DC/DC burn-in systems offers a cost effective and flexible approach to the test and burn-in of DC/DC power supplies. Systems can test a diverse range of converter types and customers can specify their choice of load including:

- Energy re-cycling
- Active constant current
- Passive resistive

Features of the DC/DC Burn-in Solution

- Continuous real time EUT monitoring
- Adaptable to a wide range of EUT types
- Data recording and statistical analysis
- Dynamic burn-in control

The diagram below shows a typical burn-in system using LoadSaver energy recycling loads.

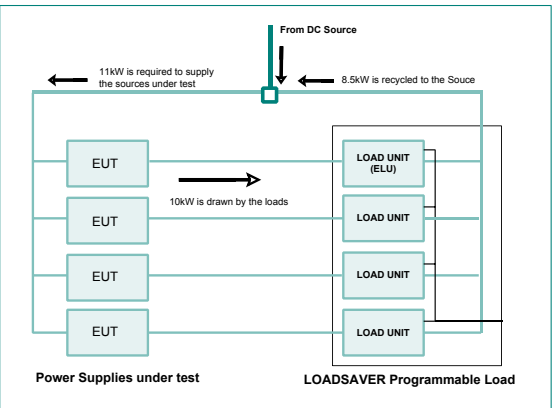

DC/DC Burn-in System Block Diagram

The DC/DC burn-in solution was designed to meet with recent trends in the power supply market such as reductions in PSU output voltages and increased current levels. These configurations implement economical full power burn-in of EUTs, using energy recycling technology ensuring lower energy costs as well as reducing the site facility installation costs.

The EUT load and real time monitoring functions are separated from the EUT carrier function. This allows greater burn-in system flexibility because a load may be applied to a variety of different types of EUT rather than being dedicated to a single EUT.

To minimise the effect of inevitable voltage drops, the EUT output voltages may be added in series, increasing the voltage supplied to the load.

Not all burn-in requirements are the same, therefore the Intepro burn-in system concept facilitates a wide variety of performance configurations. These burn-in configurations fall into four general categories as follows.

- Basic static burn-in
- Enhanced static burn-in
- Dynamic burn-in
- Enhanced dynamic burn-in

Basic Static Burn-in

Facilitates static burn-in at a constant input voltage and a constant load for a predetermined time.

- Flexible design allows burn-in of EUTs with different load requirements and input voltages
- Custom fixture design for a wide variety of EUTs, both heatsinking and non-heatsinking
- Passive resistive or active load options

Enhanced Static Burn-in

This system includes the features of the basic static burn-in system plus:

- Individual on/off control of EUTs
- Temperature sensing of the baseplate temperature
- An active constant current load
- Provision for basic EUT monitoring
- Burn-in chamber temperature control

Dynamic Burn-in

This system includes the features of the enhanced static burn-in system plus:

- Active control of loads during burn-in
- Active control of EUT input voltage
- Active on/off control of EUT
- Interfacing to LoadSaver energy recycling loads
- EUT condition monitoring
- Automatic detection of the EUT type

Enhanced Dynamic Burn-in

This system includes the features of the dynamic burn-in system as a subset plus:

- Statistical burn-in decision making
- Burn-in decisions based on factory SPC data
- Dynamic decisions on burn-in duration based on current batch statistics
- Full reporting of burn-in process statistics for input to customer SPC process

EUT Carrier Cards

EUTs are mounted on carrier cards prior to insertion in the burn-in system. This ensures that the burn-in system can be used on a wide range of UUTs.

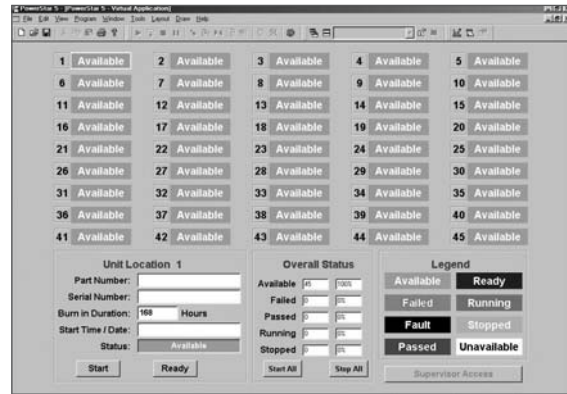

Typical Burn-in System Software User Interface

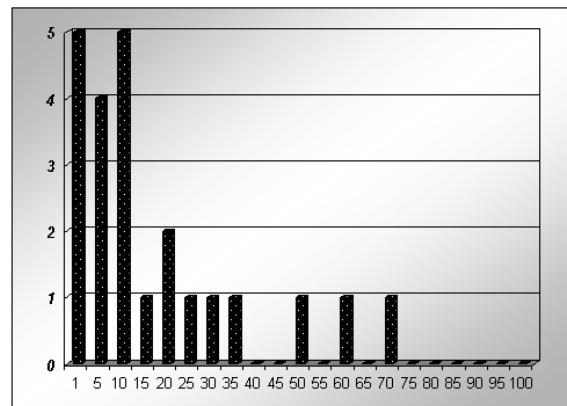

Burn-in Data Graph (detected failure versus time in minutes)

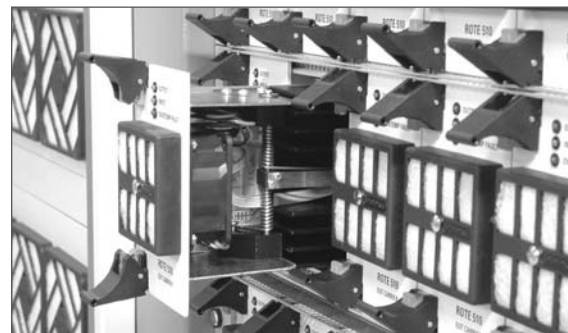

Typical Carrier Card protruding from slot

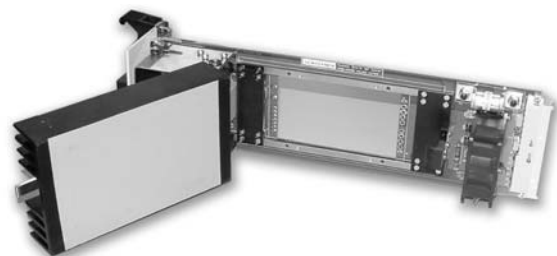

Typical Carrier Card with hinged heatsink for easy UUT loading

Typical DC/DC Burn-in Solutions

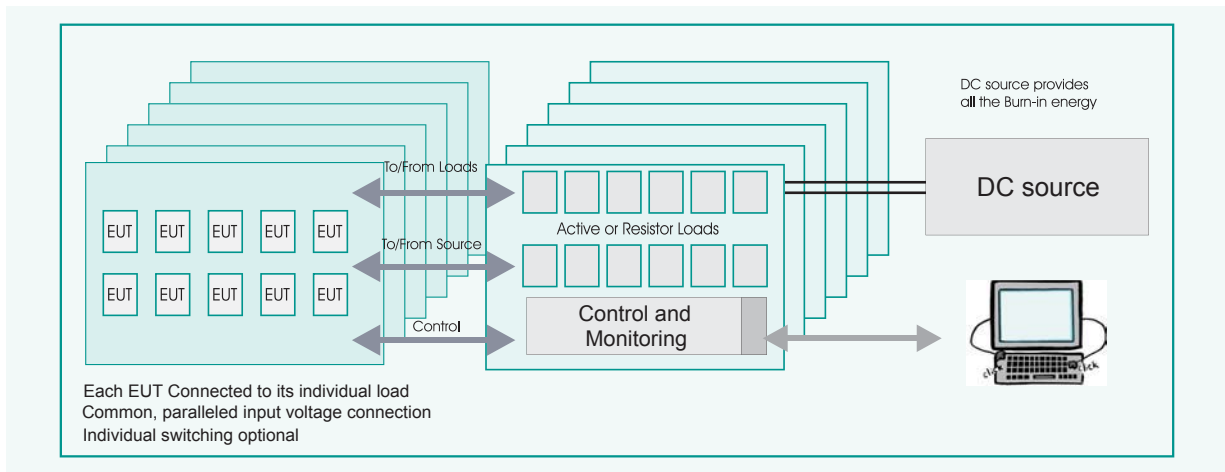

Economical Low Power Burn-in Configuration

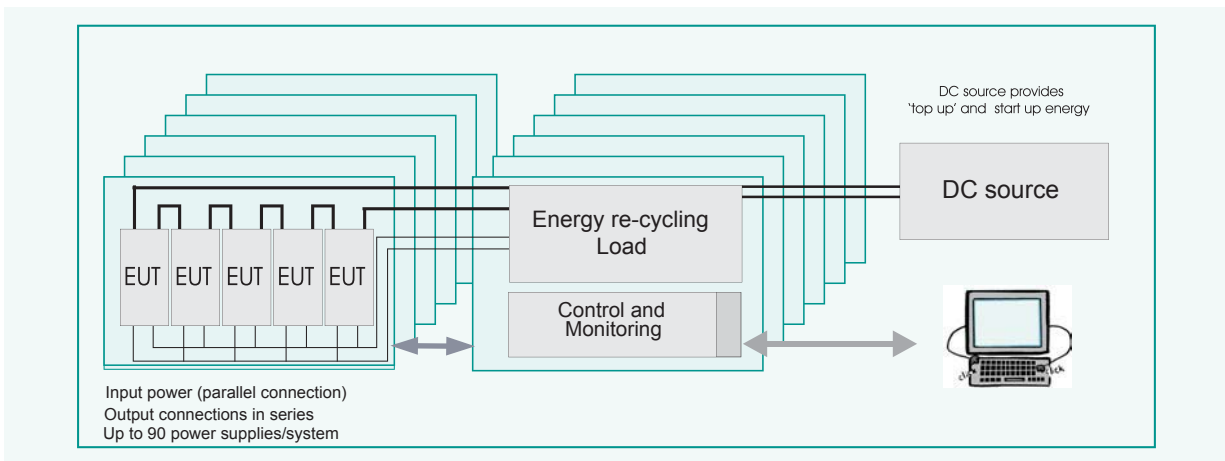

Low Voltage High Power Burn-in Configuration

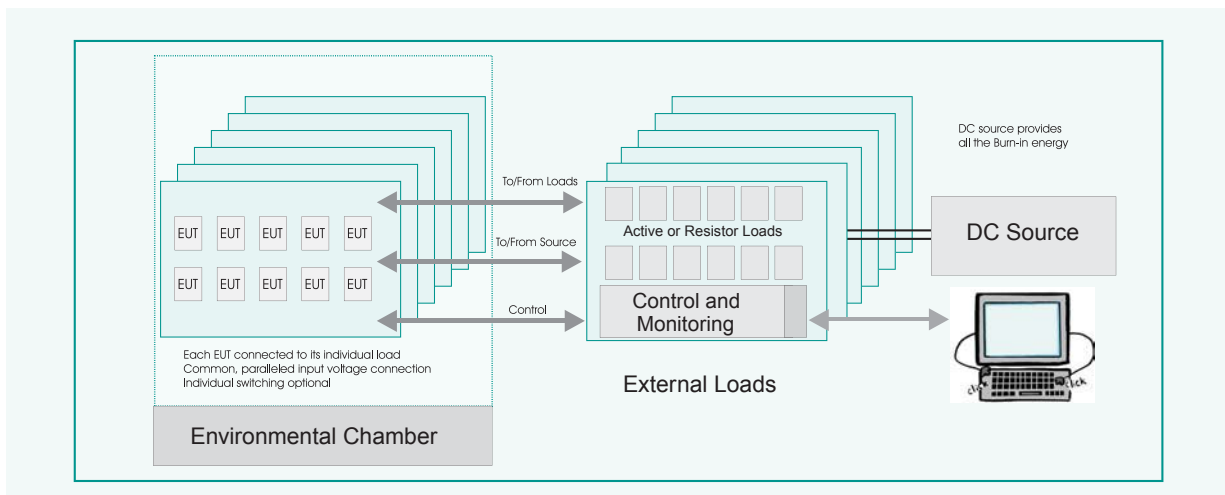

Burn-in Temperature Chamber Concept

Technical Specifications (Typical Values)



Parameter	Limits
EUT Input Voltage	To 300Vdc
EUT Output Voltage	0.8 to 60V
EUT Outputs	Triple o/p - <i>Up to 450V in LoadSaver applications</i>
EUT Output Current	0 - 100A
EUT Power	Up to 200W- <i>Higher power requires different approach to cooling</i>
Load	Up to 200W - <i>Resistors, Active MOSFET based or Recycling LoadSaver Loads may be used</i>

Real Time Fault Monitoring A variety of EUT parameters may be monitored

Temperature

EUT Ambient Temperature	125°C to -25°C
Thermal shock	(>4°C per minute)
Thermal cycling	(<4°C per minute)
	Control of EUT dwell time at high and low temperature

Dimensions

Height	30U
Depth	1m Approximately
Width	The system is built into 19" racks, one or more rack bays may be needed for a given application

Weight

Varies according to system configuration

Additional Features

Control of EUT Operating temperature, internal or ambient
 Control of input voltage, operation at low line and at high line
 Input voltage dropout testing during the burn-in cycle
 Continuous operation in fault conditions - e.g. current limit
 Mechanical shock and vibration