



Electronic Load Unit 500

LOADSAVER®

- Multi-Channel Electronic Load
- Recycles > 80% of Loading Energy
- Programmable Control and Measurement
- High Voltage Input (to 420V DC)



Electronic Load Unit 500

The LOADSAVER product family is a revolutionary, compact and cost effective approach to the test and burn-in of AC and DC sources. LOADSAVER offers a highly versatile combination of multiple programmable load units coupled to an energy recycling system.

Features of the Electronic Load Unit 500

- Highly flexible and user selectable
- Remote control and monitoring over RS485 and RS232 allow for automated process control
- Energy costs are dramatically reduced over prolonged testing, such as Burn-in
- Complicated and unreliable air handling and water cooling equipment is eliminated

The diagram below shows a typical Loadsaver configuration, with 10kW drawn from the sources under test. If these sources are 90% efficient, 11kW will be drawn from the mains. However due to the recycling abilities of Loadsaver, 8.5kW of this power shall be returned to the mains resulting in a net power draw of 2.5kW for the total system.

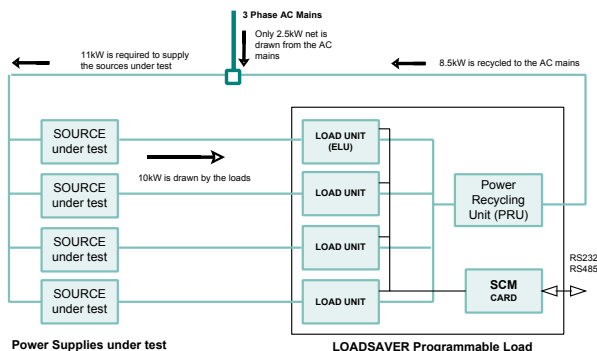

Figure 1: Loadsaver drawing 10kW from the UUT

Each electronic load unit (ELU) acts as a programmable current load under the direction of a system control and monitoring card (SCM). Loading power is not dissipated

in the ELU as with traditional loads but is transferred to the ELU output for recycling. The ELU's feed into a common output bus, which in turn feeds a single power-recycling unit (PRU). This recycling unit recycles the load energy back to a three phase AC mains.

Each ELU 500 load channel will take a DC voltage between 40 and 420V and can draw currents of up to 25A with a maximum input power of 5kW per channel. Multiple channels can easily be paralleled for higher power configurations. ELU's feeding into the same PRU share a common negative rail.

The LOADSAVER is controlled from a computer communicating over an RS232 (single drop) or RS485 (multi drop) link to the SCM card. Voltage, current and fault status may be monitored from the PC. A Windows compatible virtual instrument front end is available. Alternatively a simple but powerful command language makes it easy to incorporate the loadsaver into the user's own test program.

Two types of SCM card are available. The standard SCM controls up to 10 channels in constant current mode only. The extended version (ESCM) offers higher precision, constant current, constant resistance, constant voltage and constant power modes. An ESCM will control up to 8 channels.

In summary, the Loadsaver combines versatility while significantly reducing the energy cost of testing high power sources. It saves on installation because of the lower current feed and lower cooling requirements as in the case of more traditional Loads.

Technical Specifications

Electronic Load Unit(4U)	Input Polarity	Vin range	I _{max} /Channel	P _{max} / Channel	Channels
ELU500-420/12/ 5k/2	Positive DC	40V to 420V	12.5A	5,000	2
ELU500-420/25/10k	Positive DC	40V to 420V	25A	10,000	1

Power Recycling Unit	Max. Power	AC Supply	Power Factor	Space available	Dimensions
PFCPRU500-12	12,500W	User specified,	>0.98	12 units,	30 unit-
PFCPRU500-25	25,000W	three phase	(Load >30%)	20 with option	cabinet

Sys Cntrl. & Mntr. Card	No. of Channels	Operating Modes	Basic Accuracy	Interface
SCM-001	10	I mode	1%	RS232
SCM-002	10	I mode	1%	RS485
ESCM-001	8	V, I, R, P modes	0.2%	RS232
ESCM-002	8	V, I, R, P modes	0.2%	RS485

Family Specifications

DC Inputs

<i>Current Setting Precision</i>	0.1A SCM, 0.01 ESCM	<i>Overtemperature</i>	Automatic shutdown
<i>Step Response</i>	0.3s (<10ms with FSR option)	<i>DC Voltage out of Range</i>	Automatic shutdown
<i>Terminals</i>	10mm studs	<i>Fuses</i>	Fusing at input and output of load

AC Regeneration output

<i>No. of Phases</i>	3	<i>Recycling Efficiency</i>	85% typical
<i>Voltage and Frequency</i>	User specified	<i>THD</i>	2% at full load
<i>Terminals</i>	Screw clamp	<i>Mains Fault</i>	Internal circuit breaker
<i>Mains Loss & Overtemp.</i>	Automatic shutdown	<i>AC Power Factor</i>	>0.98 (30% to 100% load)

Auxiliary AC Supply

Safety	For control circuits: 1 phase, 115 / 230V, 50 / 60Hz, 7.2A / 3.6A
EMC	EN61010-1: 1993
CE	EN55081-2 : 1993, EN55082-2 : 1994
	Yes

Ordering Information

n x ELU500	Your choice of load units.
+ (E)SCM	Your choice of system control and monitoring card.
+ PFCPRU500	Your choice of recycling unit, you must specify AC mains voltage and frequency.

Options

20U+20U	20U+20U split cabinet option, offers 20U of space for load units (24U special available).
RS485CI/F	RS232 to RS485 converter, useful for driving multi-drop RS485 from a PC.
IEEE488CI/F	Allows the RS232 loadsaver to be used on an IEEE488 bus.
FSR	Load units adjusted for < 10ms step response.
LS_APPLET	Virtual instrument software for Microsoft Windows.