



Electronic Load Unit 60

LOADSAVER®

- Multi-Channel Electronic Load
- Recycles > 80% of Loading Energy
- Programmable Control and Measurement
- Up to 60 DC Load Channels of 3V to 60V



Electronic Load Unit 60

The LOADSAVER product family is a revolutionary, compact and cost effective approach to the test and burn-in of DC sources. LOADSAVER offers a highly versatile combination of multiple programmable load units coupled to an energy recycling system.

common output bus, which feeds a single power recycling unit (PRU). This unit recycles the load energy back to a three phase AC mains.

Features of the Electronic Load Unit 60

- Highly flexible and user selectable
- Remote control and monitoring over RS485 and RS232 allow for automated process control
- Energy costs are dramatically reduced over prolonged testing, such as Burn-in
- Complicated and unreliable air handling and water cooling equipment is eliminated

Several different load units are available in the ELU60 family, with DC voltages and currents of up to 60V and 25A per channel and power up to 375W per channel. Multiple channels can easily be paralleled for higher power configurations. Positive input ELU's feeding into the same PRU share a common negative rail. Negative input ELU's have a common positive rail, therefore, positive and negative ELU's should not be mixed in the same cabinet. A lower power ELU is available with an isolated input. This can be mixed with either positive or negative input ELU's. The ELU60 load units are installed in an LSRACK mainframe which can carry up to 10 load units and one SCM card. The positive LSRACK takes positive and/or isolated input ELU's. The negative rack takes negative and/or isolated input ELU's.

The diagram below shows a typical Loadsaver configuration, with 10kW drawn from the sources under test. If these sources are 90% efficient, 11kW will be drawn from the mains. However due to the recycling abilities of Loadsaver, 8.5kW of this power shall be returned to the mains resulting in a net power draw of 2.5kW for the total system.

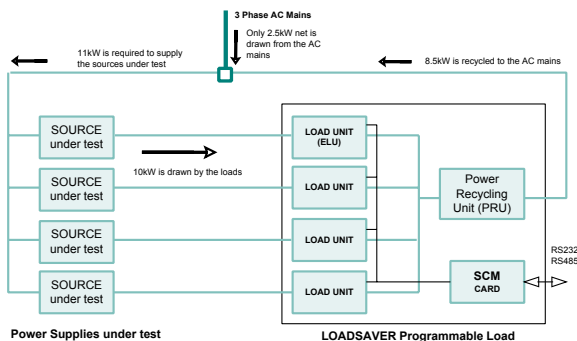

Two types of SCM card are available, the standard SCM controls up to 10 channels in constant current mode, while the (ESCM) offers higher precision, constant current, constant voltage and constant power modes. An ESCM will control up to 8 channels.

Each electronic load unit (ELU) acts as a programmable current load under the direction of a system control and monitoring card (SCM). Loading power is not dissipated in the ELU as with traditional loads but is transferred to the ELU output for recycling. The ELU's feed into a

The LOADSAVER is controlled from a computer communicating over an RS232 (single drop) or RS485 (multi drop) link to the SCM cards. An IEEE488 converter is also available. Voltage, current and fault status may be monitored from the PC. A Windows compatible virtual instrument front end is also available. Alternatively a simple but powerful command language makes it easy to incorporate the loadsaver into the user's own test program.

Technical Specifications

Electronic Load Unit	Input Polarity	Vin range	I _{max} /channel	P _{max} /channel	No. Channels
ELU60-60/25/375	Positive DC	3V to 60V	25A	375W	1
ELU60-60/25/375-N	Negative DC	-3V to -60V	25A	375W	1
ELU60-25/5/125-F	Isolated DC	3V to 25V	5A	125W	1
Sys Cntrl. & Mntr. Card	No. Channels	Operating Modes	Basic Accuracy	Interface	
SCM-001	10	I mode	1%	RS232	
SCM-002	10	I mode	1%	RS485	
ESCM-001	8	V, I, R, P modes	0.2%	RS232	
ESCM-002	8	V, I, R, P modes	0.2%	RS485	
Load Unit Rack	Input Polarity	Capacity	Dimensions		
LSRACK60/10	Positive	10 x ELU 60 + 1 x (E)SCM	19" x 4U		
LSRACK60/10-N	Negative	10 x ELU 60 + 1 x (E)SCM	19" x 4U		
Power Recycling Unit	Max. Power	AC Supply	Power Factor	Space available	Dimensions
PFCPRU60-6	6,000W	User specified	>0.98	12U	30U cabinet
PFCPRU60-12	12,000W	Three phase	(Load >30%)	20U with option	30U cabinet

Family Specification

DC Inputs			
Current Setting Precision	0.1A SCM, 0.01A ESCM	Overtemperature	Automatic shutdown
Step Response	<5ms	DC Voltage out of Range	Automatic shutdown
Terminals	4mm binding posts	Fuses	Fusing at input and output of load

AC Generation Output

No. of Phases	3	Recycling Efficiency	85%
Voltage and frequency	User specified	THD	2%
Terminals	Screw clamp	Mains Fault	Internal circuit breaker
Mains Loss & Overtemperature	Automatic shutdown	AC Power Factor	>0.98 (30% -100% load)

Auxiliary AC Supply

For control circuits, 1 phase, 115 / 230V, 50 / 60Hz, 7.2A / 3.6A	
Safety	EN61010-1:1993
EMC	EN55081-2:1993, EN55082-2:1994
CE	Yes

Options

20U+20U	20+20 split cabinet option, offers 20U of space for LSRACKS (24 Unit special available).
RS485C/F	RS232 to RS485 converter, useful for driving multi-drop RS485 from a PC.
MAN	Manual operation (no SCM card).
LS_APPLET	Virtual instrument software for Microsoft Windows.

Ordering Information

n x ELU60	Your choice of load units. Do not mix positive and negative input units.
+ m x LSRACK60	The appropriate load unit racks.
+ m x (E)SCM	Your choice of system control and monitoring cards.
PFCPRU60	Your choice of recycling unit. You must specify AC mains voltage and frequency.



Intepro Systems
1530 S. Lyon Street
Santa Ana, CA 92705
+1.714.679.9749
+1.714.835.3441 (Fax)

EU/Ireland
Intepro Systems
Lonsdale Road
National Technology Park
Limerick / Ireland
+353.61.33.22.33
+353.61.33.25.84 (Fax)

UK
Intepro Systems
Ashville Way
Molly Millar's Lane
Wokingham / UK
+44.118.977.0070
+44.118.979.2969 (Fax)