



**Measurement Module**

- **Fulfills all basic PSU measurement requirements in one module**
- **Cost efficient test at high speed with parallel measurement**
- **Multi purpose, multi channel instrument providing AC/DC voltage, frequency, ripple/noise and interval timing measurement**

This module was specially designed to provide a high-speed, complete test solution for PSU systems. This high-performance component of the Intepro 9000 system combined with PowerStar 5 software, meets all industry standard power supply measurement requirements.

**Key features of the Measurement Module include:**

- DC and AC Voltage Measurement
- RMS and Peak to Peak Ripple Noise Measurement
- Frequency Measurement
- Programmable Input Thresholds on timing Channels
- 10 Input Scanning Matrix
- Parallel Operation
- GPIB Interface



Measurement Module

Key to the Measurement Module's operation are the two powerful DSPs located on the Digital Board. Controlled by PowerStar 5 they provide the necessary processing power for today's high speed production test environment.

The Measurement Module is made up of the following functional blocks:

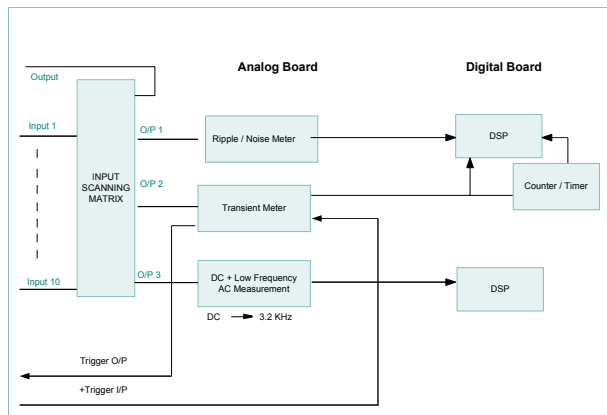

Measurement Module Block Diagram

**Ripple Noise**

The ripple/noise meter measures RMS and peak to peak ripple/noise on the outputs of the UUT. It is possible to include or reject low frequency hum and to set the upper bandwidth of the measurement to exclude unwanted high frequency components.

**Timer**

Measures rise/fall times, inter-rail timing, programmable thresholds and slopes on two channels. There are 2 programmable analog channels and one TTL channel, each programmable channel can have two thresholds and slopes programmed.

**DC and AC Voltage Measurement**

Full auto ranging on all AC and DC inputs.

## Technical Specifications

<b>Frequency Measurement Ranges</b>	30Hz to 750kHz, 30Hz to 150kHz (user selectable)
<b>Programmable Threshold Range</b>	±100V DC
<b>DC Input Voltage Range</b>	<b>Accuracy</b>
0-600mV	±0.05% of Range
0-2V	±0.03% of Range
0-6V	±0.02% of Range
0-20V	±0.02% of Range
0-60V	±0.02% of Range
0-100V	±0.02% of Range
<b>DC Input Impedance</b>	1MΩ
<b>AC Input Voltage @ 50Hz</b>	<b>Accuracy</b>
0-400mV rms	±0.1% of Range
0-1.4V rms	±0.1% of Range
0-4.2V rms	±0.1% of Range
0-14V rms	±0.1% of Range
0-42V rms	±0.1% of Range
0-70V rms	±0.1% of Range
<b>Interval Timing</b>	2 analog channels, 2 programmable thresholds and slopes per channel, 1 TTL channel
<b>Bandwidth</b>	1MHz
<b>Measurement Range (Time)</b>	5μs - 10s
<b>Accuracy</b>	±2μs
<b>Threshold Accuracy</b>	±1% of DC input voltage range
<b>Ripple Noise</b>	
Voltage Range Peak to Peak	50mV, 200mV, 500mV, 2V
Bandwidth	5kHz to 20MHz
Accuracy	±5% of range
Measurement Window	Programmable 1ms-200ms
Minimum Noise Measurement	10mV Pk-Pk, 3.5m Vrms
<b>Operating Conditions</b>	
Operating Temperature	5°C to 40°C
Storage Temperature	5°C to 70°C
Humidity	10% to 85% relative
Safety	Meets the safety guidelines laid down in the EN 61010-1 standard
<b>Ordering Information</b>	
Part number	714-0001
Description	Intepro 9000 Measurement Module PMM 9010



**Intepro Systems**  
1530 S. Lyon Street  
Santa Ana, CA 92705  
+1.714.679.9749  
+1.714.835.3441 (Fax)

**EU/Ireland**  
Intepro Systems  
Lonsdale Road  
National Technology Park  
Limerick / Ireland  
+353.61.33.22.33  
+353.61.33.25.84 (Fax)

**UK**  
Intepro Systems  
Ashville Way  
Molly Millar's Lane  
Wokingham / UK  
+44.118.977.0070  
+44.118.979.2969 (Fax)