



Intepro 9000 Series

Relay Scanner Module

- **14 Scanner Relay channels per module (100V)**
- **Facilitates System Selftest down to module level**
- **10 Free Relays (4A)**

The Relay Scanner Module is a dual purpose instrument. It acts as a reference and switching module for system Selftest, which is used in conjunction with a Selftest fixture and Selftest software. When the Relay Scanner is not in use as a Selftest application, it is available to be used as a general purpose scanning and switching card. The Relay Scanners in-built selftest is an essential component for “down” time minimisation in any high volume manufacturing facility.

The Selftest facility is designed to help diagnose a failure down to the module level and in many cases component level. For example; checking system free relays will test each individual relay in both the open and closed position and identify a specific faulty relay on a free relay module.

Components of the Selftest option include:

- (1) Intepro 9000 Relay Scanner Module
- (2) System Selftest Fixture
- (3) Selftest Software Package

The system Selftest fixture does not contain any active electronic components. Its purpose is to interconnect various parts of the system across the front panel; use of a simple passive (wiring only) Selftest fixture ensures a reliable Selftest option.

The Selftest software is structured in a modular fashion to check each of the “sub-systems” in the



Relay Scanner Module

overall Intepro 9000 configuration. For example a separate check exists for DC sources, AC sources, Loads, Relays and so on.

The Selftest software will setup the Intepro 9000 Relay Scanner Module to provide the relevant stimulus for each test block in Selftest. Selftest will generally checkout the complete chain of modules involved in a sub-system. One example would be, checking a system DC source, Selftest will control the DC source driver card and (via the Selftest fixture) connect the output of the source back to a suitable measurement unit and verify the programmed source voltage level. This verifies that not only is the driver card and DC source functional but that the wiring from the driver card to the source and the wiring from the source to the front panel is also operational.

The Intepro 9000 Relay Scanner Module is designed for simple plug in insertion into an Intepro 9000 Hybrid rack. Connection is via one 50 Way D Type connector and two 25 Way D Type connectors.

Technical Specifications

Circuit Functions

Reference	5VDC/2.5VDC
Sine Reference	8Vpp@1.25kHz
Triangle Wave	8Vpp@1.25kHz
Square Wave1	24Vpp@1.25kHz
DC Pull-up	12V@150mA
Current Shunt	0.11Ω ±1%

Scanner Relays

14 channels per module (100V@100mA)

Free Relays

10 relays per module (30VDC@4Amps)

Module Characteristics

Dimensions	261mm(H) x 220mm(D) x 50mm(W)
Operating Temperature	5°C to 40°C
Storage Temperature	-25° to 70°C
Humidity	10% to 85% relative non condensing

Ordering Information

Part Number	714-0008
Description	Intepro 9000 Relay Scanner Module RSM 9010

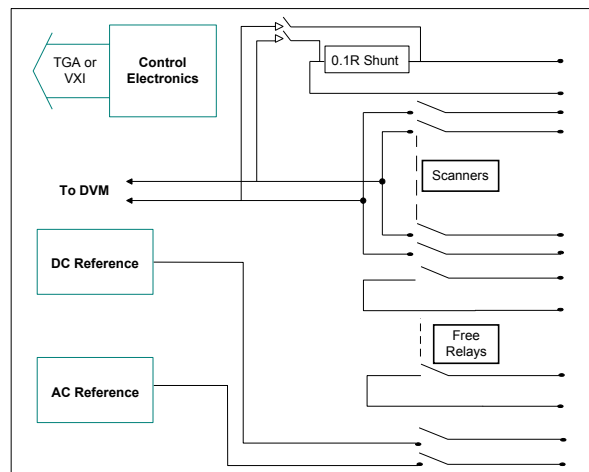

Relay Scanner Block Diagram



Intepro Systems
 1530 S. Lyon Street
 Santa Ana, CA 92705
 +1.714.679.9749
 +1.714.835.3441 (Fax)

EU/Ireland
 Intepro Systems
 Lonsdale Road
 National Technology Park
 Limerick / Ireland
 +353.61.33.22.33
 +353.61.33.25.84 (Fax)

UK
 Intepro Systems
 Ashville Way
 Molly Millar's Lane
 Wokingham / UK
 +44.118.977.0070
 +44.118.979.2969 (Fax)